

Vernon Tool®

Pipe Cutting Machines



1170 Trademark Drive—Suite 101
Reno, Nevada 89521
800-571-1066
775-673-2200
www.vernontool.com

LINCOLN®
ELECTRIC

**Cutting
Systems**

Welcome to Vernon Tool

Vernon Tool's commitment to pipe fabrication

- Pipe cutting technology has advanced rapidly since the days of the hand-held torch and the wraparound paper template. Today, a single cutting machine can supply profiled pipe that will engage the services of up to 10 fit-up and welding stations. The advancements are continuing with Vernon Tool leading the way.
- Vernon Tool Company acquired manufacturing rights for the patented Douglas cutting machine, a simple mechanical pipe-cutting pantograph for straight cuts, simple miters, and saddles, in 1948. During more than sixty ensuing years of "Made in USA" history, we at Vernon Tool have continued to improve our earned reputation for reliability, longevity, and dedicated customer support.
- Vernon's commitment to the fabrication market can be seen in its investment in design engineering, advanced technology, and experienced service staff.
- By aligning its interests with those of its customers and continuously exchanging information, Vernon Tool has forged customer relationships that have existed for more than forty years. The common goal of improving productivity with regular innovation has produced a shared experience of loyalty and respect.

“Safety, speed, and quality” are the benchmarks of profitable pipe fabrication—and these are the qualities that describe Vernon Tool pipe cutting machines.

Knowledgeable business owners recognize the reality that a centralized, efficient cutting process controls the speed of all downstream operations.

Table of Contents

Performance engineered products	4
Common applications.	6
Vernon Tool MPM machine configuration	8
Shop layout recommendations	9
Pipe handling equipment	10
Competitive comparisons	12
Pipe cutting time studies.	13
Mechanized cutting options	14
Computerized profiling assemblies	15
Dedicated software	18
Optional accessories	20
MASTERPIPE® Compact Profiler	24
Low-cost software for high-productivity	26

Our ongoing commitment

- While many of the original pipe cutting and material handling concepts are still valid today, Vernon Tool incorporates the very newest technology in our machines. Innovations such as:
 - Programmable logic controls
 - Network-compatible operating systemshave led to:
 - Reduced costs
 - Improved cut accuracy
 - Decreased redundant data entry
- Vernon Tool recognizes that the key to our future is continuous product improvement and your satisfaction as a customer. That is why we remain solidly committed to improving your overall pipe cutting operations. Eight hundred installations worldwide attest to our success toward this goal.

Performance engineered products

Simple material set-up and accurate pipe profiles

- Mechanization of cutting improves the speed and repeatability of each cut and a ruggedly built machine promotes an easy set-up, so we have engineered the Vernon Tool machines to exceed in speed and strength:
 - A bolt together machine bed supports turning rolls. These rotate the pipe as the cutting torch cuts it. The pipe is self-centering in the turning rolls.
 - The cutting carriage travels on precision machined and hardened ways by means of a solid rack and pinion gear drive. The torch needs only to be raised and lowered to accommodate different diameters. Pipe cutting, with excellent operator visibility, can be performed anywhere on the machine.
 - To minimize wear and increase machine life, the pipe's weight is distributed evenly over the length of the machine bed.
 - Machine motion using closed loop position encoder feedback makes cuts that are exactly repeatable under computer numerical control (CNC).
- Since excellent machine performance is our assurance of your satisfaction, each and every software detail is engineered to improve production and decrease costs.



Safe and efficient pipe handling

In 1965, Vernon Tool innovation integrated powered pipe conveyors within the turning roll machine bed. Since then, machine setup and material handling times have been reduced by up to 80 percent.

Pipe is power-moved into the cutting area, then hydraulically lowered onto the powered turning rolls which control the cutting movement, again raised from the turning rolls, then power-discharged from the cutting area quickly and easily ... all from the operator's console. The operator can concentrate on cutting activities instead of pipe handling.

Both the finished piece and the remnant are fully supported, rotated, and moved without the need for additional labor or lifting devices.

Streamlined data flow

- All cutting operations are controlled by one person from the operator's console, where cutting data is entered on a screen with a graphic representation of the profile connections and holes, or data saved from previous cuts may be quickly reloaded. No programming skills or other special operating skills are required to obtain precise, repeatable cuts.
- The Microsoft Windows®-based pipe cutting software, WinMPM, developed by Vernon Tool, collects cut data and converts it into machine motion instructions. The interaction is easy-to-follow, so operators enjoy a fast learning curve and simple start-up. In addition, built-in validity checking helps catch any errors before a cut begins, saving time and material.
- Reusable part-cutting programs are created at the machine console, by the team's designated engineer on a remote PC, or loaded by importing from popular 3D pipe modeling programs, such as Tekla®, MultiSTEEL, and Acorn Pipe Systems.
- Without intermediate steps, the CAD designed parts can immediately be CAM cut, eliminating redundant data entry and its concurrent human errors, as well as time-consuming manual conversions.



Common applications

Offshore and structural support piping

- Fabricators of offshore jackets, bridges, architectural space frames, and lifting cranes employ pipe in load bearing, welded framework structures. The creation of a compound, overlapping joint with complex centerline and axial offsets is now a common task for the fabricator, and the cost of field erection and rework dictates that clean, tight fit-ups, such as those produced by a Vernon Tool machine, are the rule, not the exception. Vernon computerized machines eliminate virtually all manual lofting, measuring, and marking operations.
- The effect of producing accurate, high quality cuts under CNC control with your Vernon Tool machine, is to convert regular pipe fitters into highly productive pipe welders, who can concentrate on producing high quality connections, instead of spending valuable time “dressing” unsatisfactory profiles.

Industrial piping

- Process piping applications include tubular sections through which a gas, fluid, slurry, or fluidized-solid may flow. Such piping is commonly cut by mechanical and industry-based contractors in the construction of many kinds of projects. These include petrochemical plants, paper and pulp mills, power generation plants, HVAC systems, ships, and oil and gas transport pipelines—among others.
- To save both time and money, many modern projects rely on prefabricated piping components, called pipe spools, consisting of measured lengths of pipe joined to fittings or other components prior to delivery to a job site. The use of spools that are designed to precisely fit the final assembly avoids the added complexity and cost of fabrication on site. With a Vernon Tool machine, the multiple pipe components of various spool assemblies can be arranged for cutting in the exact order required, so they can move, as in a production line, from raw storage to spool fabrication to the job site, employing quality-control conditions at each step.



Pressure vessel fabrication

- Where pipe serves for containment, pressure vessel fabricators employ Vernon Tool machines in the manufacturing of components such as heat exchangers, compressors, separators, pumps, boilers, and turbines because the Vernon Tool machines will produce components to the necessary exacting specifications.
- Operators can produce vessel shells and nozzles, each with a precise distance and axial location between the cuts. Manual measuring, marking, and grinding are virtually eliminated using our computerized cutting machines. Further, the correct constant weld prep angles required by the ASME can be produced automatically while cutting profiles with certain Vernon Tool machines.



Over its long history, the name “Vernon Tool” has been synonymous with “pipe-cutting machines” in a wide variety of industries. General or specialized fabricators in the fields of process piping, power generation, mechanical contracting, pressure vessel manufacturing, and structural frames rely on Vernon Tool for high production and precise fit-up.

Vernon Tool MPM machine configuration

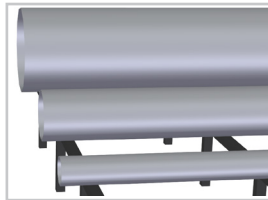

A. Load the pipe onto the storage racks next to the entrance conveyor.

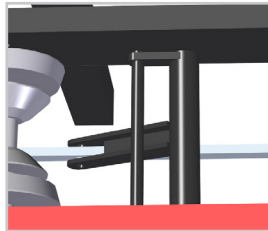

B. Raise the selector gates flush with the storage rack. Roll the pipe onto the conveyor.

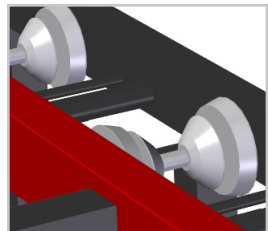
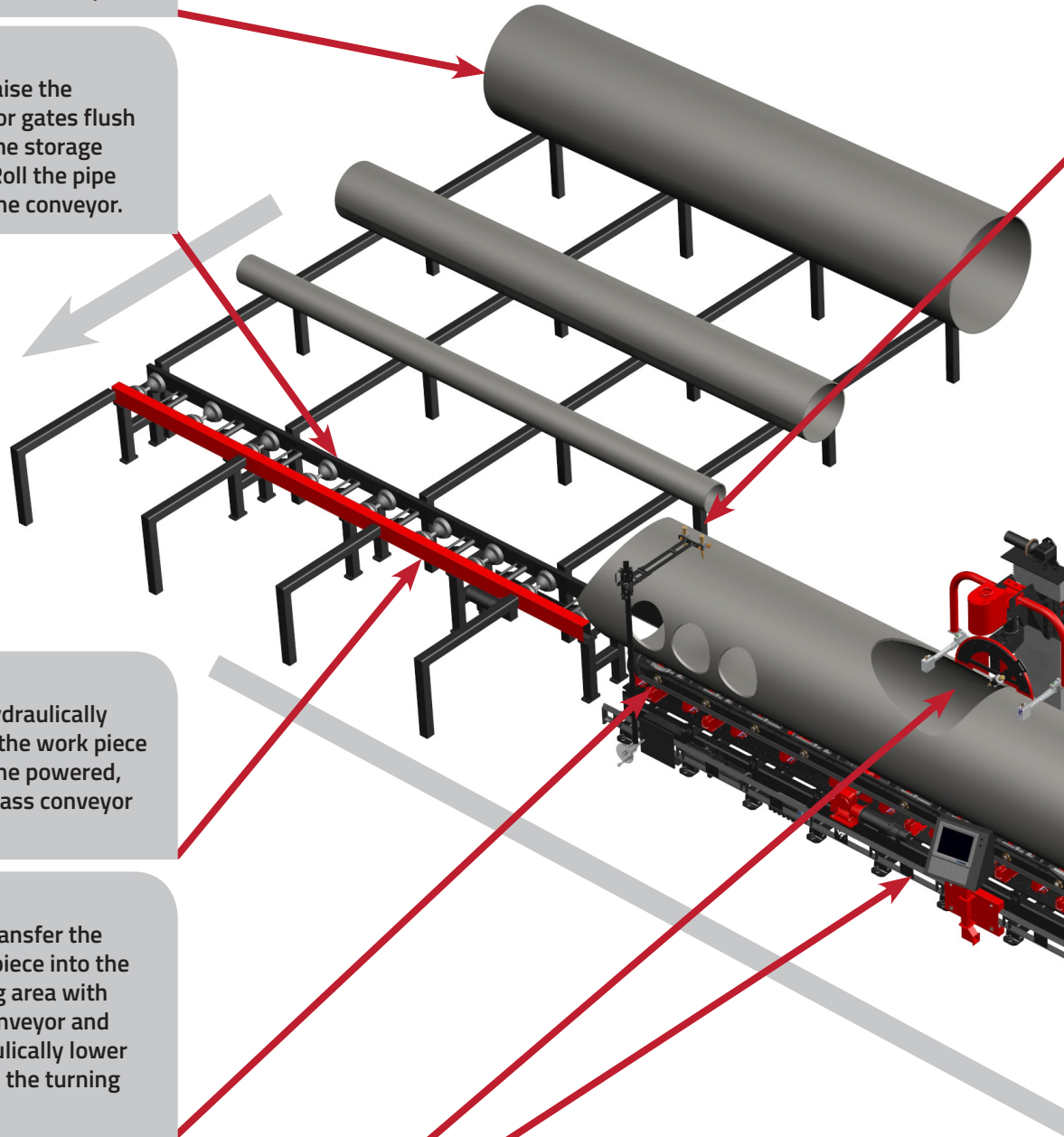

C. Hydraulically lower the work piece onto the powered, hourglass conveyor rolls.

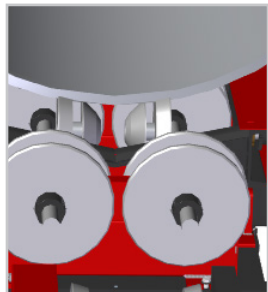

D. Transfer the work piece into the cutting area with the conveyor and hydraulically lower it onto the turning rolls.



E. Load the desired program and produce the cuts with the profiling assembly.

The Vernon Tool engineers will not only provide all the foundation drawings for your installation, they will discuss various options you might have for material flow.

Shop layout recommendations

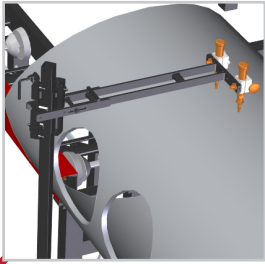

F. Optionally, make beveled end and beginning cuts with the two-torch straight cut-off assembly.

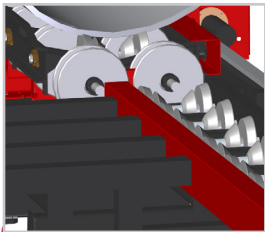

G. After cutting, lift/convey the pipe from the turning rolls onto the discharge conveyor.

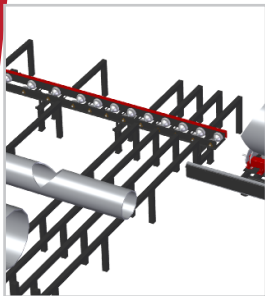

H. Raise the selector gates and discharge the cut pipe to the racks. Position the remnant for repeat cuts or return it to the rack.

“Custom” is standard at Vernon Tool

- For more than 60 years and with the experience from more than 800 installations world-wide, we have confirmed that no two customers are alike, so we tailor each installation for specific pipe sizes and lengths. Our multi-axis computer controls get matched to your intended application.

Complex cuts are computer precise, while the material handling system loads pipe quickly and safely.

The shapes of end profiles and holes are produced by coordinating several axes of motion. Vintage mechanical pantograph models formerly employed adjustable cams and levers, but Vernon Tool MPM models rely on powerful CNC-driven motors.

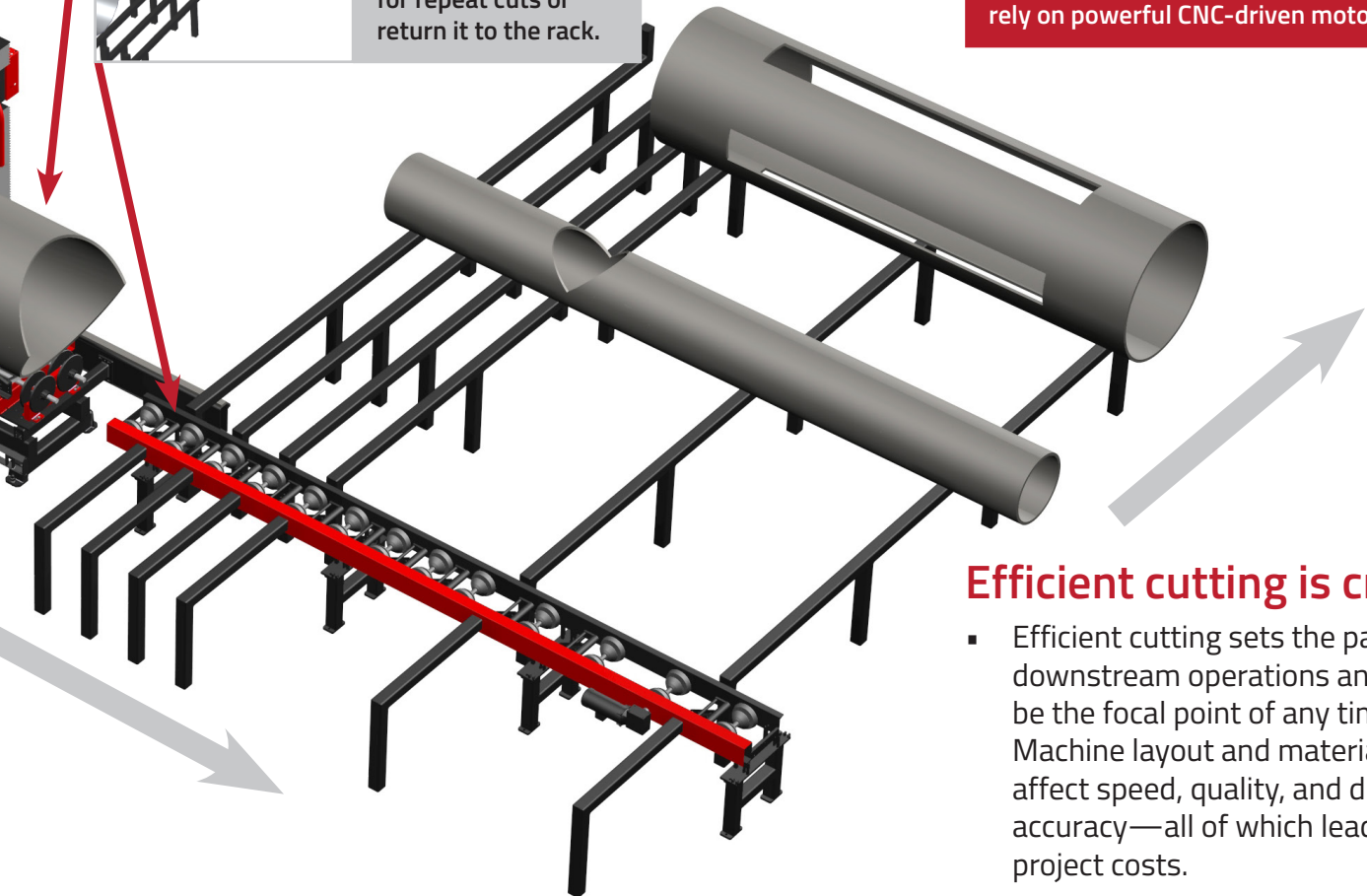

Efficient cutting is critical

- Efficient cutting sets the pace for all downstream operations and should be the focal point of any time study. Machine layout and material flow affect speed, quality, and dimensional accuracy—all of which lead to lower project costs.

Pipe handling equipment

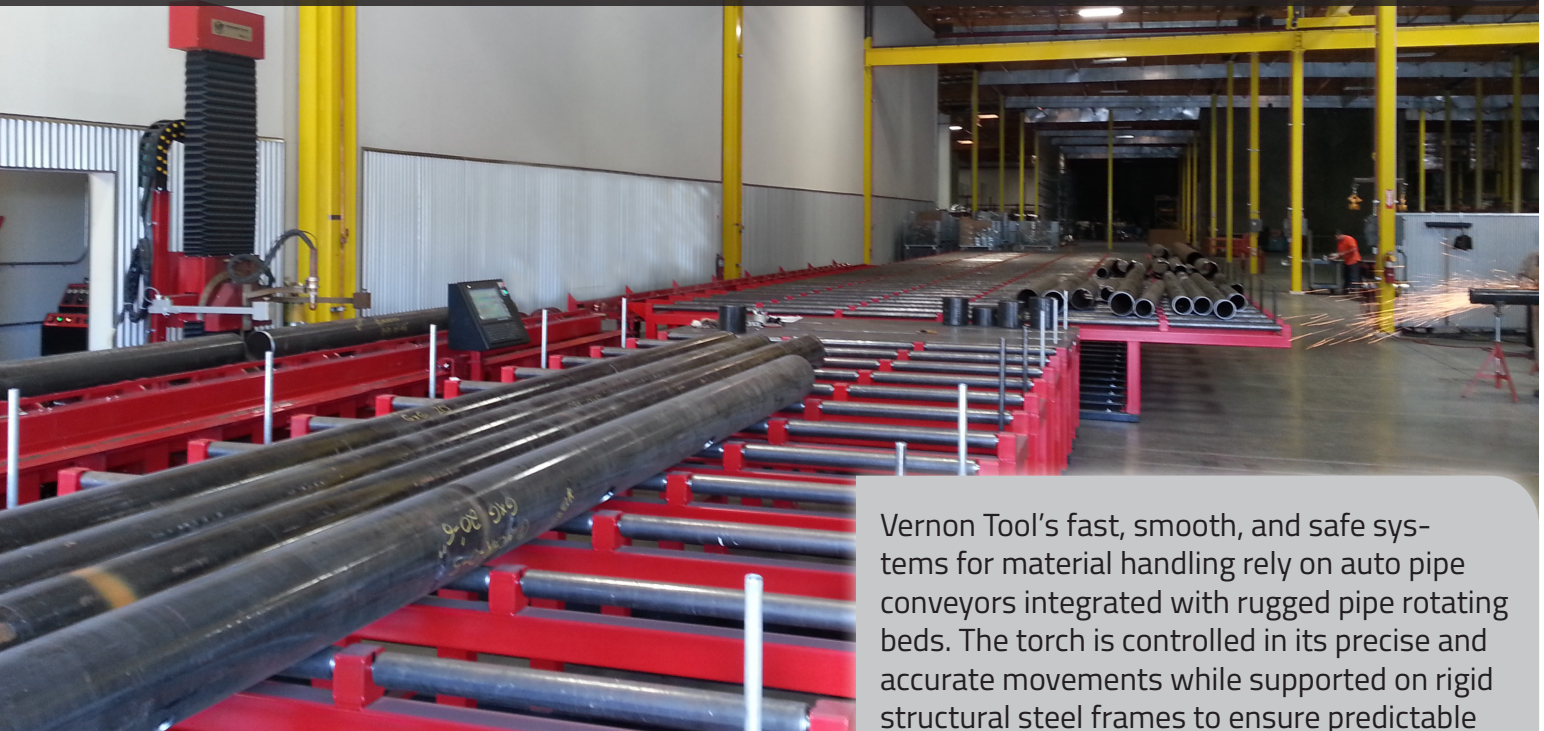

Vernon Tool's fast, smooth, and safe systems for material handling rely on auto pipe conveyors integrated with rugged pipe rotating beds. The torch is controlled in its precise and accurate movements while supported on rigid structural steel frames to ensure predictable operation and unmatched longevity.

Turning roll and conveyor assembly

- Vernon Tool machine beds employ a rigid structural steel frame supporting two smoothly rotating, parallel drive shafts running in heavy-duty roller and thrust bearings, with turning rolls located along the entire length. The shafts are driven by a CNC-controlled variable speed DC motor through two minimized-backlash worm gearboxes.
- When placed on the turning rolls, the pipe centers itself and is ready to cut. The various available models accommodate a wide range of pipe diameters, and only the cutting torch must be raised or lowered to adapt to different diameters.
- The standard Vernon Tool machine is capable of conveying and rotating a single random (20-22 foot) length of pipe. Optional machine extensions provides full rotation and support for double or triple random lengths up to 66 feet long. Extensions are made identically to the standard machine bed and directly connect to the main drive shafts, lifter-conveyor frame, and straight cut-off carriage track of the base machine.
- The lifter-conveyor assembly, consisting of hourglass shaped rollers on a welded frame, uses hydraulic power to lower and raise pipe out of the rotation rollers. Sealed ball bearing flange units on the roller shafts and the DC drives ensure smooth, trouble-free lateral movement of the pipe.



Entrance conveyor

- Similar in design to the machine's lifter-conveyor assembly, entrance conveyors load pipe into and out of the cutting machine bed. Structural steel frames secure a series of hourglass rollers on shafts in flanged ball bearings. Linked by chain and sprocket assemblies, the conveyor rollers are controlled by a variable speed, reversible DC drive motor.
- Hydraulically-actuated selector gates raise and lower pipe onto and off of the rollers to the height of the adjacent pipe storage racks. In the full UP position, the selector gates are flush with the storage rack so that a pipe can easily be rolled from rack to conveyor. When the correct pipe is placed over the conveyor, the selector gates are lowered and the pipe is cradled by the conveyor rollers.



Gates up position allows pipe to be rolled from the entrance side onto the conveyor.

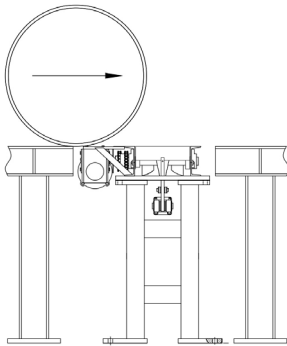

Gates down position cradles pipe in the conveyor for transportation into the cutting bed.

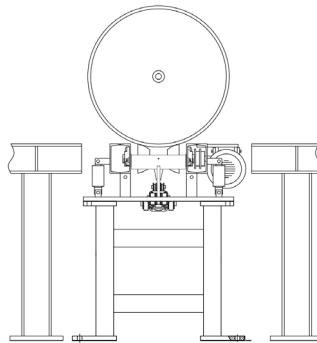

Gates up tilt rolls the pipe (to either side) to discharge beds and finished pipe racks.

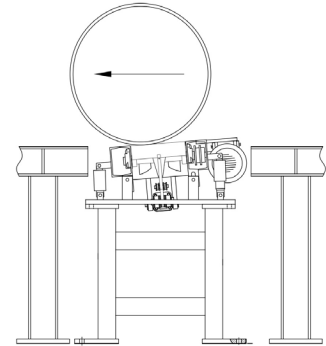

Discharge conveyor

- After all cutting operations are complete, the finished pipe is power rolled onto the discharge conveyor where it is raised out of the hourglass rollers by hydraulic selector gates. Then, hydraulic cylinders tilt the conveyor in either direction to roll the finished pipe onto the finished pipe storage racks.
- All conveyor functions, like power-feed-direction and speed, selector-gate UP/DOWN, and hydraulic discharge tilt are selected from the operator's console, so that a single operator completes all the loading and cutting processes.



Competitive comparisons



Turning roll bed conveyors make the difference

Turning roll versus chucking machines

- The primary advantage of Vernon Tool Pipe Cutting equipment is our roller bed and conveyor design that offers heavy-duty reliability, safe and simple operation, and efficient material handling. The powered pipe conveyors ensure optimum speed, maximum safety, machine longevity, and reduced labor hours. A single operator manages all loading and cutting operations from the operator's control console.
- During cutting, the pipe is fully supported and rotated on a bed of turning rolls. Regardless of pipe size or cut complexity, set-up consists of merely raising or lowering and starting the cutting torch. Vernon Tool machines make all common cuts found in process, pressure vessel, and structural fabrication.
- By comparison, chucking machines rotate pipe by clamping it in adjustable jaws. Typically, pipe is end-loaded and centered relative to the fixed height of the chuck. When the chuck cannot hold the weight of the entire length of pipe, outboard supports must be raised or lowered to support longer lengths. This complexity imposes stress on the machine and slows production.

Pipe cutting time studies

Material handling typically represents 80% of the time to get pipe cut, so it is critical to load, set-up, and unload pipe as efficiently as possible. Any comparison of our machines against manual methods or competitive machines will clearly show the Vernon Tool time savings.

First cut sample: Oxy-fuel with two saddles

End #1:
6" O.D. x .281" wall on 6" O.D. at
45-degrees

End #2:
6" O.D. x .281" wall on 6" O.D. at
45-degrees

Distance:
72" between end #1 and end #2

Step	Time
1. Conveyor moves pipe into cutting area	0:43
2. Operator enters cut variables on console	1:34
3. Microprocessor calculates path	0:10
4. Operator positions torch over start point	0:30
5. MPM 5 cuts end #1 with oxy-fuel	2:52
6. MPM 5 rapid traverses to end #2	0:49
7. MPM 5 cuts end #2 with oxy-fuel	2:39
8. MPM 5 returns to program start	0:42
9. Conveyor moves finished piece from cutting area	0:15
Total time per part (in minutes)	10:14

Second cut sample: Plasma with K-saddle and miter

End #1:
20" O.D. x .500" wall on 36" O.D.
and 36" O.D. at 90-degrees with
90-degree roll angle

End #2:
20" O.D. x .500" wall to plate at
30-degrees

Distance:
66" between end #1 and end #2

Step	Time
1. Conveyor moves pipe into cutting area	0:40
2. Operator enters cut variables on console	1:25
3. Microprocessor calculates path	0:16
4. Operator positions torch over start point	0:30
5. MPM 5 cuts end #1 with plasma	1:17
6. MPM 5 rapid traverses to end #2	0:50
7. MPM 5 cuts end #2 with plasma	1:10
8. MPM 5 returns to program start	0:42
9. Conveyor moves finished piece from cutting area	0:12
Total time per part (in minutes)	7:02

The following speeds used are typical for time estimates:

Load, move, and unload pipe	60 feet/minute.
Carriage rapid traverse	16 feet/minute.
Oxy-fuel cutting	15 inches/minute*
Plasma cutting	50 inches/minute*

*For common wall thicknesses from 1/4" to 3/4"

Mechanized cutting options



Mechanizing the cutting operation results in repeatable cuts, high in quality, and free from human error. The movable torch carriages allow all diameters to be cut to the desired length without any interference along the machine bed and in full view of the operator.

Two-torch straight cut-off assembly

- The two-torch straight cut-off assembly option produces pipe spool components to length with straight and beveled end cuts. Two torches make cuts simultaneously, one on the trailing end of the first piece and one on the leading edge of the next piece.
- The operator moves the rolling torch carriage to the proper distance on the machine, locks it into position according to a tape measure mounted on the machine frame, and conveys the pipes against a retractable pipe stop. While cutting is performed, steel wheels mounted next to the torches maintain a constant tip-to-pipe distance.

Computerized profiling assemblies

Behind the torch: strength and brains

- Computer controls synchronize the torch movement with the rolling of the pipe while cutting and also manage pipe handling functions. PLC technology provides the coordination of auxiliary machine functions like torch on-off and automatic out-of-round compensation.
- Sturdy construction using low-backlash worm drives, machined and hardened ways, and precision heavy-duty rack and pinion drives furnishes your assurance of repeatability and longevity. DC servo motors with encoder feedback provide repeatable accuracy.
- A ruggedly built industrial computer provides multi-axis motion controls, fast calculations, large data storage, and design software specific to pipe profiling operations.
- Windows®-based programming means fully supported network compatibility to generate, transfer, and archive pipe programs. Programs may be created at the machine console or downloaded from the designers' remote machines. The computer-controls also provide maintenance diagnostics.

Touchscreen technology literally puts production line productivity at your fingertips, so you can quickly and accurately process all types of pipe profiles and holes.

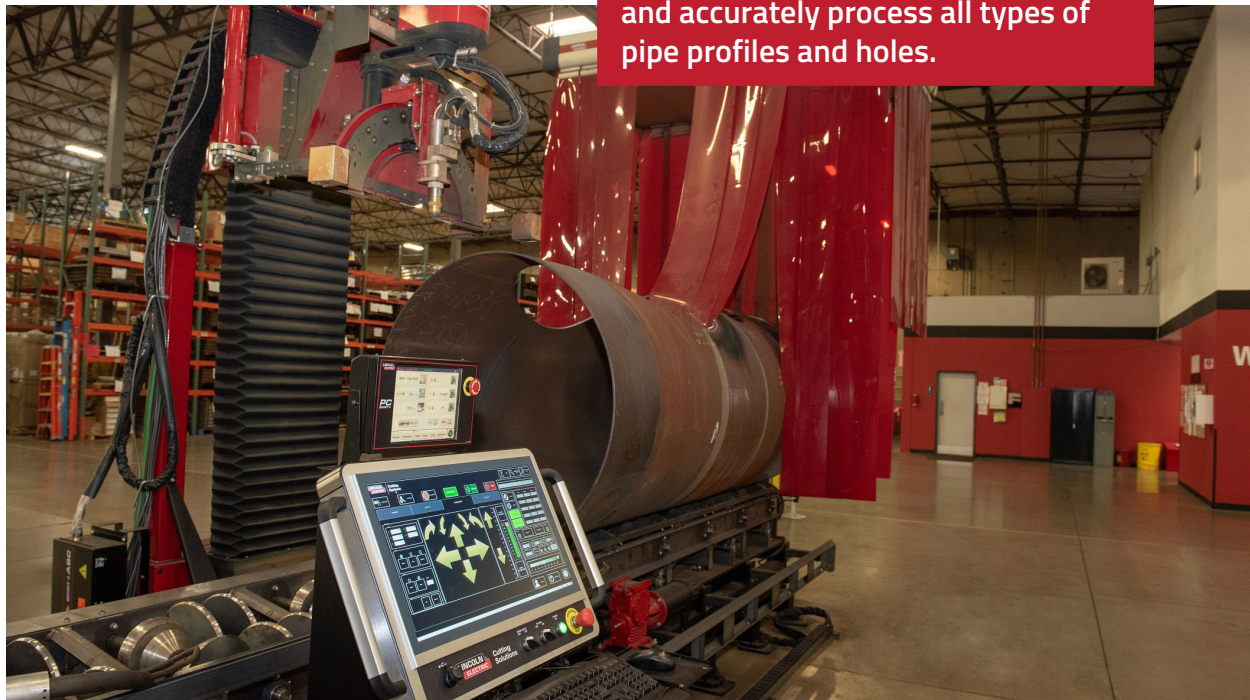

Controllers to match requirements

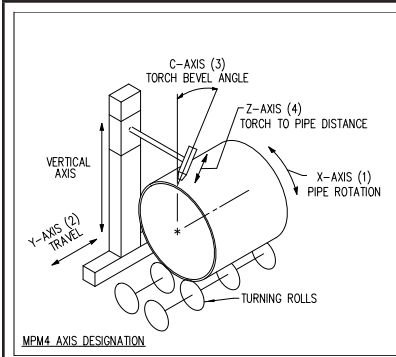

MPM-4

- The 4-axis control, Model MPM-4, incorporates four axes of motion to orient the torch to the proper weld preparation angle and to maintain the proper distance between the torch tip and pipe. This produces a constant included weld prep angle between the adjoining pieces. The computer control compensates length measurement regardless of weld prep angle.
- Automatic out-of-round compensation is accomplished by analog proximity sensors on an independent closed-loop servo circuit. The cutting carriage and operator's console travel the full length of the machine.

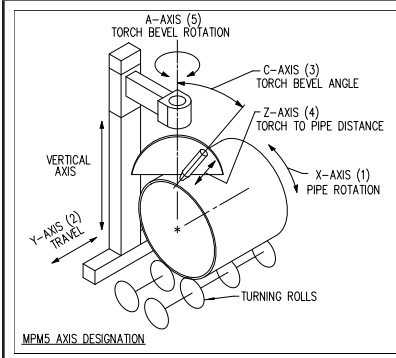

MPM-5





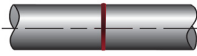
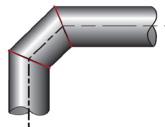

- The 5-axis control, Model MPM-5, adds an axis of motion to rotate the torch bevel angle so that it remains normal to the contour cut path. To produce a constant weld prep angle, the machine can burn any desired bevel angle at any location on the pipe.
- The principal benefits of this assembly are slightly faster cutting speeds and very accurate weld preparation angles common in offshore construction and pressure vessel fabrication.
- Automatic out-of-round turning compensation uses analog proximity sensors on an independent closed-loop servo circuit.

Legend	A	All bevel cuts have full weld prep	C	Cuts usually require some manual weld prep
	B	Bevels may not need manual prep; depends on weld spec	N	Not supported as a cut type

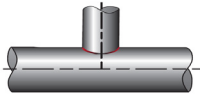
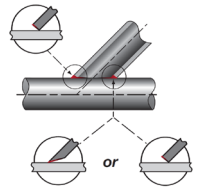
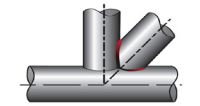
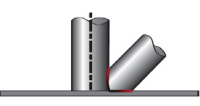
Cutting matrix

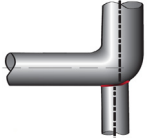
Cut Type	MPM-5	MPM-4	MPCP
 Straight	A	A	A
 Miter	A	A	A

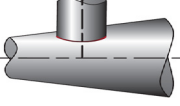
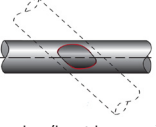
Cutting matrix (continued)

Cut Type	MPM-5	MPM-4	MPCP
 <p>Tee</p>	A	B	C
 <p>Saddle (Std or AWS ID/OD)</p>	A	B	C
 <p>Multi-saddle</p>	A	B	C
 <p>Multi-saddle-miter</p>	A	B	C
 <p>Double miter</p>	A	B	C
 <p>Elbow support</p>	A	B	C
 <p>Circular/saw cut/rect.</p>	A	B	C
 <p>Pipe to cone</p>	A	B	C
 <p>Overlap (boat bumper)</p>	A	B	C
 <p>Reinforcing pad</p>	A	B	C
 <p>Gusset slots</p>	A	B	C

Dedicated software



The Windows®-based operations software offers simple start-up and easy maintenance.

Real-time operations

- The WinMPM operations software is common to all Vernon machines and ensures reliability, user familiarity, and maintenance continuity.
- A simple “fill in the blank” data entry screen, graphically represents the pipe being cut. It also hides the powerful computations and complex geometric algorithms used to calculate the intricate machine movements from the operator.
- As soon as an operator completes the data entry, in either imperial or metric units, the software checks for calculation errors and displays both a graphical view of the pipe that rotates through 360 degrees and a “flat unrolled” profile to allow visual parameter verification.
- Each part program contains front and rear end profiles and an almost unlimited number of circular and rectangular holes with exact sizes, placement, and axial angles. The programs can be quickly saved and re-loaded later. All layout and burning operations are consolidated into a unified procedure.
- To simplify operation and maintenance, the console includes a large touchscreen monitor. It displays interactive error messages, labeled illustrations, color-coded “button” graphics, and an on-line instruction manual.

Off-line software

- Network compatibility gives management the ability to delegate part-programming responsibilities to the shop floor or to remote engineering centers. In addition, you can directly import CAD-CAM files from popular 3D pipe and tubing modeling programs, including Tekla®, MultiSTEEL, and Acorn Pipe Systems.
- Isometric, structural, and pressure vessel design programs generate data files that are easily received and converted into Vernon Tool machine formats. Redundant data entry and human errors are eliminated.
- Offline generation of customized cut sheets containing intersection data, 3D and 2D dimensioned images, materials, quantities and customer or project identification for distribution to the shop floor lets the operator simply load the file by name and begin to cut.



Internet-based factory service

- The Vernon on-line diagnostic service, **logmein123.com**, connects factory technicians to your machine using an Internet link that is high-speed, secure, and dedicated. On-site operators and technicians communicate in real-time with Vernon Tool factory experts who supervise, demonstrate, and troubleshoot software and hardware problems.
- With logmein123.com, the technicians can review data files, set up machine parameters, and update the operating system. Whenever needed, step by step instruction is available with on-line messages and a live “whiteboard” illustrator.

Internet technology puts factory technicians virtually side-by-side with your staff.

Optional accessories

Plasma cutting

- All Vernon machines are readily adaptable to plasma power supplies for cutting carbon and stainless steel, alloy materials, and aluminum. Plasma cutting yields a smaller heat-affected zone with less material distortion than oxy-fuel cutting, with three to five times faster cutting speeds (and no preheat delay) so cutting times and clean-up labor are considerably reduced.

Rotating grounds

- When using plasma arc with the Vernon Tool machine, the rotating ground is attached to the pipe to direct the plasma return circuit current back to the power source. This avoids damage to the machine's moving parts and electrical components. The rotating ground has a magnet, which is inserted into the pipe and travels with the pipe as it is conveyed on the machine.

Oxy-fuel preheat torch

- 5-axis computerized models can be fitted with a preheat torch to improve the speed and quality of oxy-fuel cuts on material with a large wall thickness. The preheat torch travels ahead of the cutting torch under either program or manual control. Automatic ignition, solenoids, valves, regulators, and hoses are included with this option.

Fume extraction

- Lincoln Electric's Modular Extraction Hood contains and extracts welding, cutting, and other fumes from the work environment. With a Statiflex filter bank, the hood provides internal dynamic filtration during cutting. Many other fume control options are available for a custom solution for your facility.





MASTERPIPE® Compact Profiler



Use plasma to cut tube products like handrails, structural frames, and nozzles with production line speed.

The optional WinMPM software has user-friendly controls to generate cut files for straight cuts, centerline offsets, T, K, & Y profiles, slots, and holes.

Economical CNC Pipe Cutting Solution

- The MASTERPIPE Mini Profiler is a three-axis, CNC pipe cutting machine capable of production cutting and profiling of pipe with an outside diameter of two to eight inches and a length of up to 25 feet, with a maximum pipe diameter of 12 inches and 1000 lbs of total weight.
- Featuring a rugged design and powered by the VMD or Accumove, the MASTERPIPE Mini Profiler improves pipe fabrication productivity and quality by consolidating set-up, programming, and cutting in an easy operation. The Driver software imports from many CAD/CAM packages including the WinMPM software.
- The WinMPM option is easy to use and does not require highly skilled operators. An operator can just select a type of cut from a list, enter the size and angle data, and transfer the file to the Driver, where setup is quick and free from trouble.

Features

- Modular expansion—start with a five foot bed and add five foot extensions, up to 25 feet, to improve productivity by using fewer operations.
- Easy loading—one button easily moves the torch carriage near the chuck so that material can be easily and safely loaded, positioned for cutting, and unloaded.
- Consistent plasma quality and arc length—the optional Arc Voltage Height Control (AVHC) achieves cleaner cuts on pipes and tubing that is “out of round.”
- Cleaner work environment—compressed air removes smoke and fumes from pipe.
- Logmein123.com remote Internet diagnostics and assistance—maximizes up-time.

Configuration

- The standard MASTERPIPE uses a manual-angle, manual height-control for the plasma torch. For achieving cleaner cuts on larger diameter material that may be slightly out-of-round, the Arc Voltage Height Control (AVHC) option keeps the same arc length, and same quality, throughout the cut.

Material range

- Large or small diameter material? Long or short material? The automated profiler's variable-jaw chuck handles outside diameters from one to twelve inches (two to eight in production). The smallest sized profiler has a footprint of only two feet wide and seven feet long. It rapidly finishes four foot material and by adding five-foot long extension modules, the MASTERPIPE Mini Profiler can grow to hold material of up to 24 feet in length.
- To determine cutting speed, amperage, and torch height, identify the material type and wall thickness.

Easy loading

- One button can move the torch mount so that material can be loaded and positioned for cutting. Large or small diameter pipe is supported by a set of easily adjustable ball transfer cradles that can be repositioned away from the cutting action. Adjustable gas-shock chuck supports make it easy to accurately set and lock the chuck height to ensure smooth and level rolling of different diameter material on the cradles.
 - The plasma torch work-lead cable attaches directly to a permanent rotating chuck-connector to provide a "no step, no worry," positive arc current flow. You can quickly position the torch by jogging, including an easy manual adjustment for torch bevel to decrease hand grinding and weld preparation finish work. These features all reduce the time between cutting operations and lead to real efficiency improvements.



Low-cost software for high-productivity

WinMPM understands pipe cutting

- The best combination for affordable hardware and software to operate the Vernon Tool MASTERPIPE Mini Profiler is a Microsoft Windows® computer, with Accumove and the WinMPM software. WinMPM generates G-code that executes in the Driver software to control the VMD. This controller has been used effectively on thousands of CNC cutting system X-Y tables.
- The more industrial grade Vernon Tool cutting machines simply use WinMPM integrated hardware and software, providing design, G-code generation and execution, plus pipe handling and movement, all on the same screen.

The key to automation efficiency is CNC: the processing of computer generated G-code to produce the precise motion that results in fast, accurate cutting.



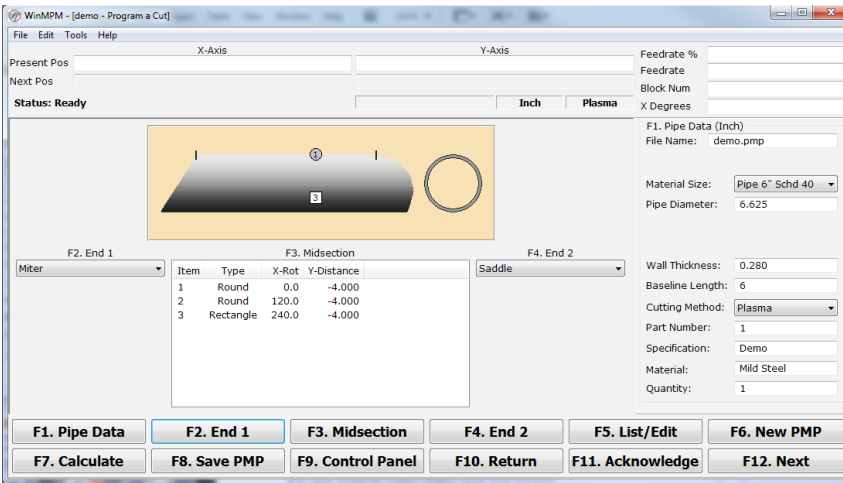

WinMPM design software enables the custom profiling of both ends of the pipe, as well as cutting holes in the midsection of the pipe to attach round or rectangular tubing at any angle. Select from miter, saddle, straight, crown, elbow support, or pipe-to-cone for the ends. For any of the multiple holes you may cut in the midsection, select from round, rectangle, saw cut, bumper, or re-pad.

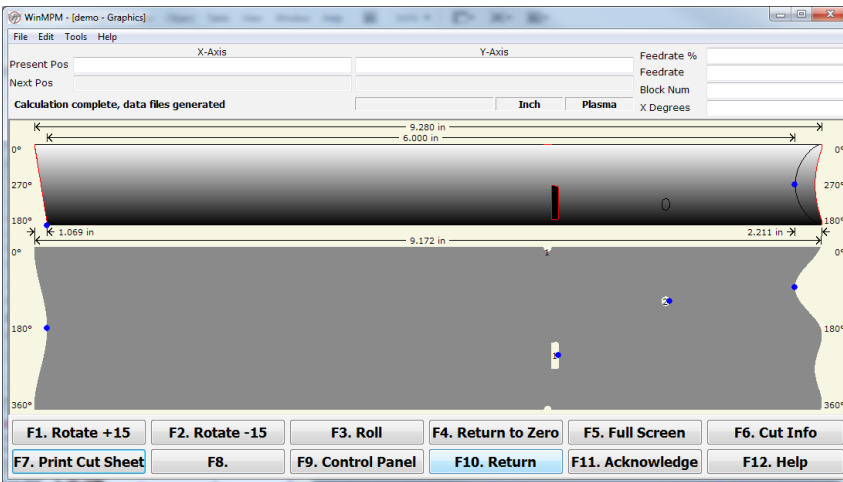

After calculating the cut paths and checking for errors, WinMPM design software provides a rolling animated view of the pipe as it will be cut, as well as an "unrolled" cutting pattern.

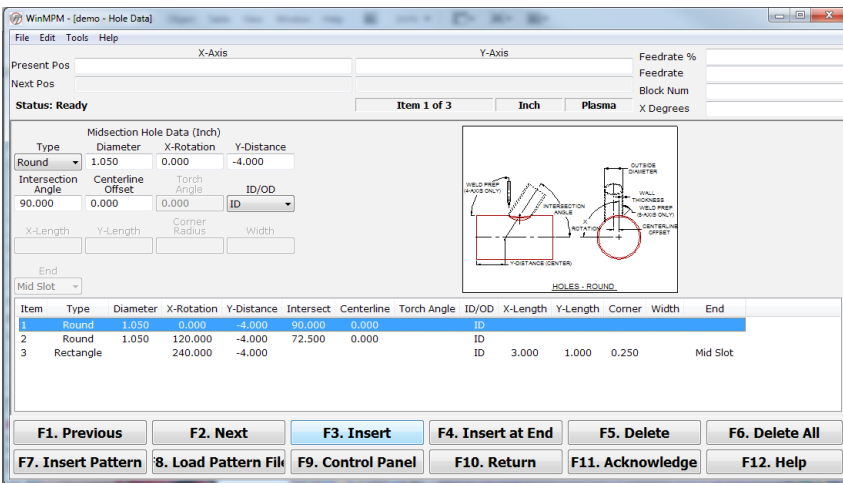

Cut holes and profiles for intersecting pipe with precision and accuracy using the WinMPM software. Simply enter the parameters by referring to the displayed diagrams, load the pipe into position, and begin cutting.

Notes

